

Gravity and low pressure die casting of aluminium alloys: a technical and economical benchmark

F. Bonollo, J. Urban, B. Bonatto, M. Botter

Among the innovative and conventional foundry processes for Aluminium alloys, low pressure die casting is characterised by several advantages, including high yield, excellent control of operative parameters, good metallurgical and technological quality. This process is often (and incorrectly) associated only to the production of automotive wheels, while it is improving its potential both towards other automotive components and non-automotive parts. The paper is aimed at showing the potential of low pressure die casting for the production of safety boxes, to be employed in chemical, petrol and off-shore plants. This potential is examined both in technical and economical terms, and is compared with that offered by other conventional Aluminium foundry processes, such as permanent mould gravity diecasting.

Keywords: aluminium alloys, foundry, low pressure die casting, defects, materials characterisation, equipments

INTRODUCTION

The increasing number of applications and of products is the best proof of the success of Aluminium alloys foundry. This is probably one of the most dynamic fields inside manufacturing and engineering. The well-known advantages associated to the use of Aluminium alloys (light weight, good mechanical behaviour, good corrosion resistance, etc.) constitute the driving force for the introduction, on one hand, of new applications and design and, on the other hand, for the development of new processing solutions. Various processes are now competing, to achieve both economically and technologically advantageous production of Aluminium alloys castings. The general scenario is described in a quite wide literature [1-10] and is schematically shown in Figures 1a (part-process-weight chart) and 1b (process vs quality – in terms of gas entrapment – chart).

Among the most interesting processes, low pressure die casting is certainly worth mentioning, thanks to its peculiarities, allowing, in several cases, an excellent compromise between quality, costs, productivity, geometrical feasibility. Even if such a process is quite old (the first patent, concerning casting of lead alloys, was deposited in England in 1910), its significant industrial application started thirty years ago [8]. Nowadays, it is adopted for casting Aluminium- and Magnesium-based alloys. The principle of this process is quite simple: the permanent die and the filling system are placed over the furnace containing the molten alloy (Fig. 2) [1-6]. The filling of the cavity is obtained by forcing (by means of a pressurized gas, typically ranging from 0.3 to 1.5 bars) the molten metal to rise into a ceramic tube (which is called stalk), which connects the die to the furnace (Fig. 3). Generally speaking, the pressure used is roughly equivalent to 2 meters of an Aluminum column.

Once the die cavity is filled, the overpressure in the furnace is removed, and the residual molten metal in the tube flows

again towards the furnace. The various parts of the die are then separated, and the casting is finally extracted. Specific attention has to be paid to the design of the die, to control by means of proper cooling circuits, the solidification path of the alloy. The massive region of the casting has to be the last one to solidify and must be placed near to the

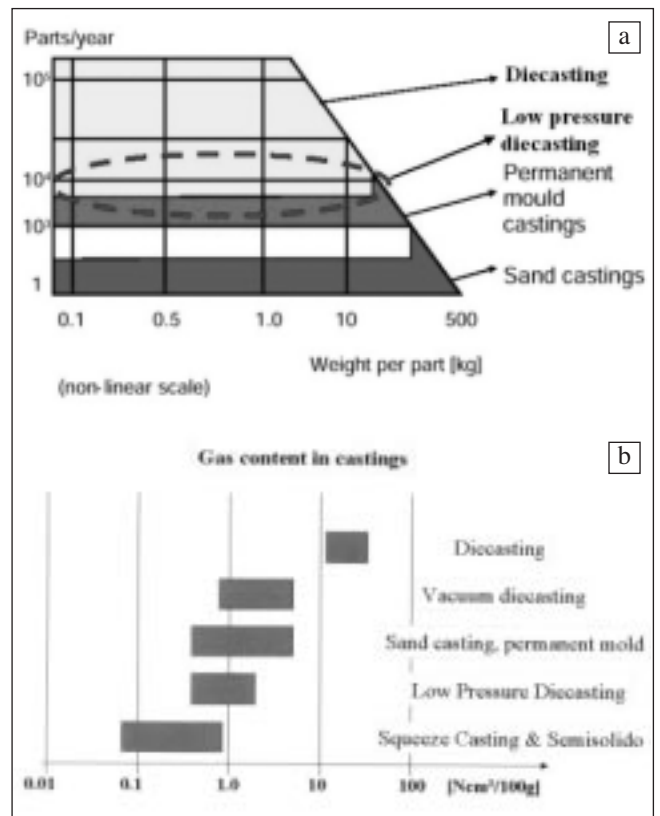


Fig. 1 – Field of convenience of foundry processes as a function of production rate and casting weight (a); comparison of foundry processes in terms of gas content in castings (b).

Fig. 1 – Campi di convenienza dei processi di fonderia in funzione della produzione richiesta e del peso dei getti (a); confronto tra i processi di fonderia in termini di contenuto di gas nei getti (b).

F. Bonollo, J. Urban

DTG - University of Padova, Vicenza - Italy (bonollo@gest.unipd.it)

B. Bonatto - LPM, Padova - Italy

M. Botter - Elfit, Villesse (GO) - Italy

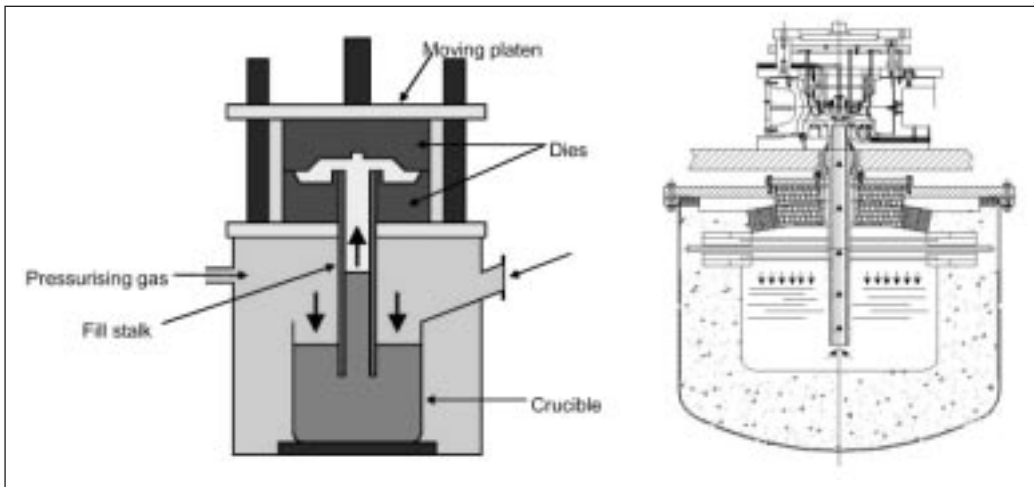


Fig. 2 – General scheme of the low pressure die casting process.

Fig. 2 – Schema di principio del processo di colata in bassa pressione.

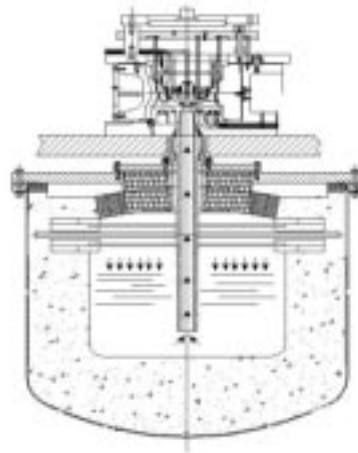
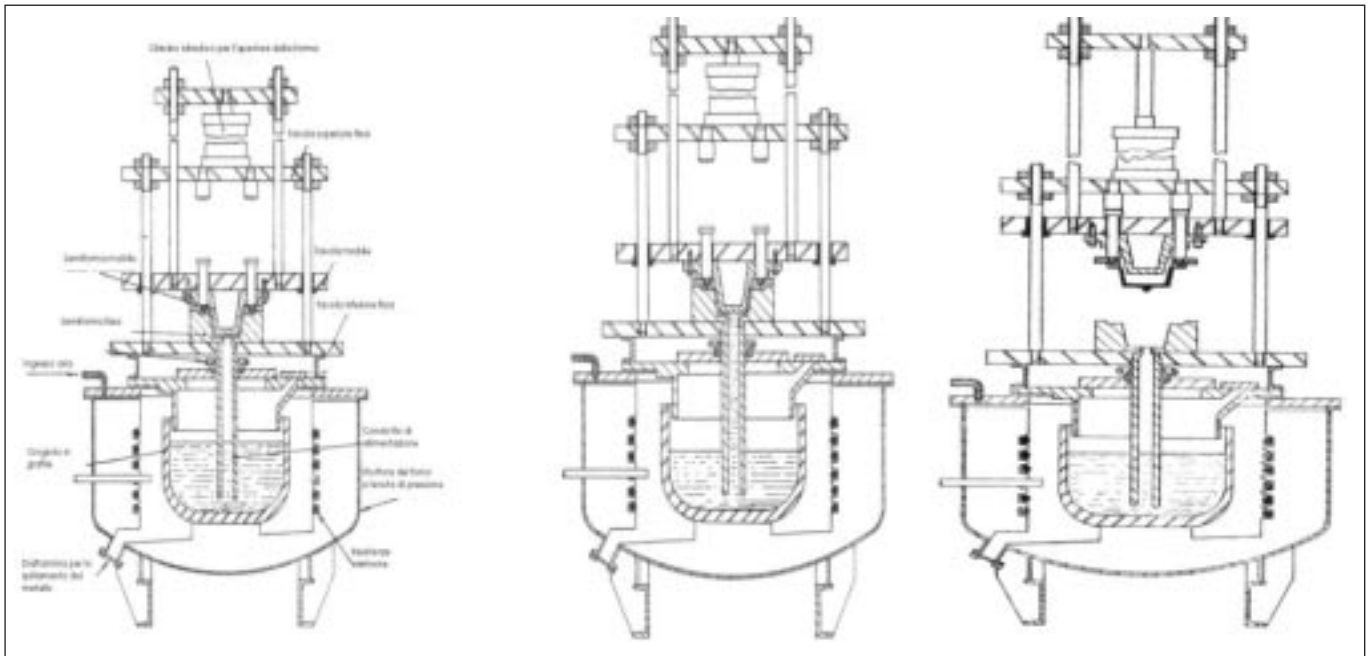


Fig. 3 – Working sequence in the LPDC process [8].

Fig. 3 – Sequenza operativa del processo di colata in bassa pressione [8].



stalk, which acts as a “virtual” feeder and allows to avoid the use of conventional feeders, thus improving the yield of the process, which becomes significantly high. The low injection velocity and the relatively high cycle time lead to a good control of the fluid-dynamics of the process, avoiding the defects originated by turbulence phenomena. Castings up to 70 kg weight can be produced, with tolerances of 0.3-0.6 %.

The die can be design for the production of a single casting or for multiple castings, according to the size required and to the characteristics of the machine.

The advantages of low pressure die casting process are several:

- the high yield achievable (typically over 90%)
- the reduction of machining costs, thanks to the absence of feeders,
- the excellent control of process parameters which can be obtained, with a high degree of automation,
- the good metallurgical quality, thanks to a homogeneous filling and a controlled solidification dynamics, resulting in good mechanical and technological properties of the castings.

The applications of low pressure die casting in the automotive field are several, even if this process is often (and reductively) associated only to the production of wheels (Fig. 4a). Some examples of low pressure die casting products are collected in Fig. 4b.

In this paper, the potential of low pressure die casting for the production of safety boxes, to be employed in chemical, petrol and off-shore plants, will be illustrated, both in technical and economical terms. The information presented will allow a comparison with other conventional Aluminium foundry processes, such as permanent mould gravity casting.

THE COMPONENTS INVESTIGATED

The components selected for the presented study are safety boxes and covers (Fig 5) produced by ELFIT SpA by means of different processes. The boxes are obtained by low pressure (LPDC) and gravity die casting (GDC), while the covers are obtained also by sand casting (SC) and high pressure diecasting (HPDC). The composition of castings depends basically on the processes adopted; in detail

- the alloy EN AB-43000 (AlSi10Mg) has been used for LPDC;
- the alloy EN AB-44100 (AlSi13) has been used for GDC;
- the alloy EN AB-47100 (AlSi12) has been used for HPDC;
- the alloy EN AB-42000 (AlSi7) has been used for SC.

On the castings, radiographic examinations, hardness tests and microstructural investigations (light microscopy and image analysis) have been carried out, to achieve an extended comparison among their characteristics.

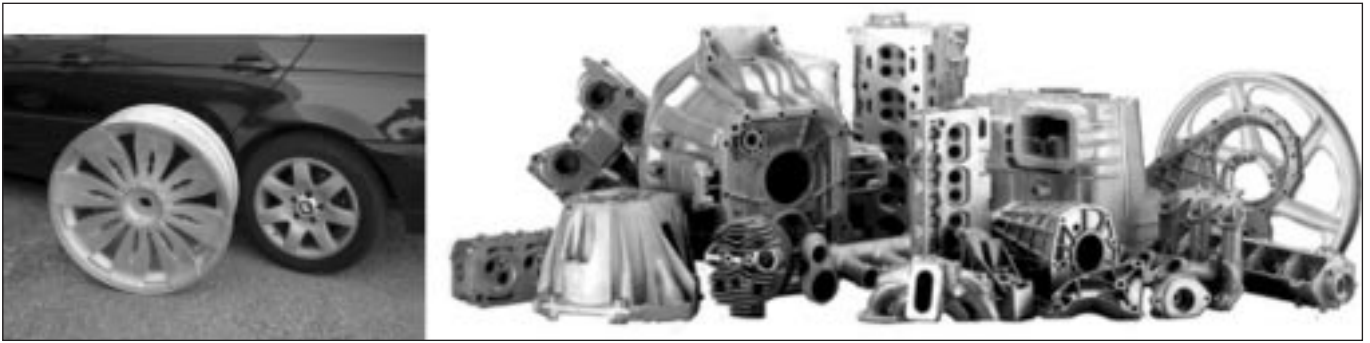


Fig. 4 – Examples of castings produced by means of the LPDC process [16].

Fig. 4 – Esempi di getti prodotti mediante colata in bassa pressione [16].

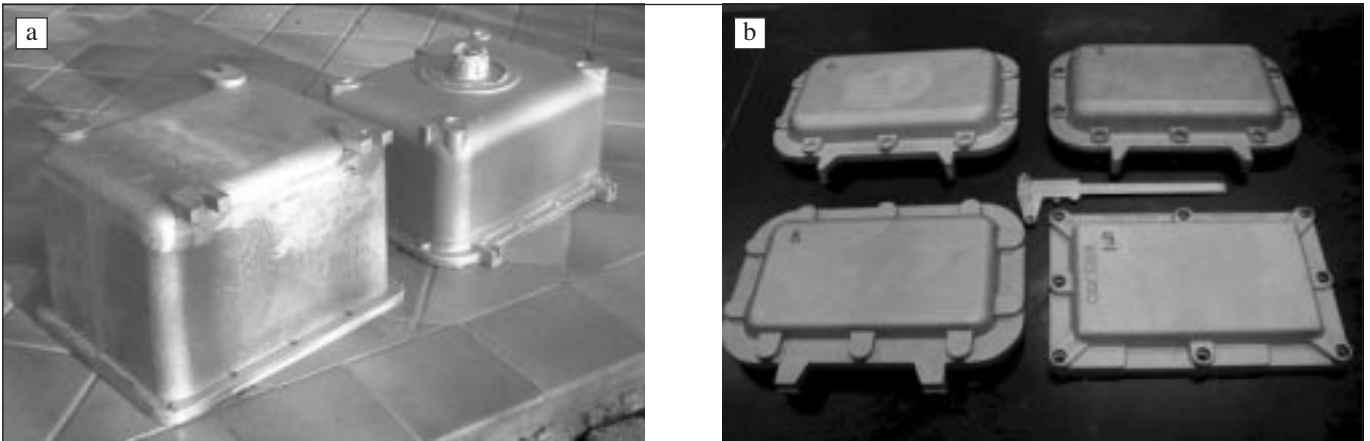


Fig. 5 – The components investigated in the present paper: safety box (a) and safety covers (b).

Fig. 5 – I componenti oggetto del presente lavoro: contenitore di sicurezza (a) coperchi di sicurezza (b).

RESULTS OF EXPERIMENTAL INVESTIGATIONS

Radiographic Inspection

For what concerns the boxes, the most critical zone, in the case of LPDC, has been individuated to be the corner, with some clustered porosity; on the other side, the content of porosity in the walls is quite low. In the case of GDC, the corners typically present relatively big cavities, even if in a lower number with respect to LPDC; the walls evidenced some cavities.

The radiographic quality of boxes and covers is described in Figs. 6-8. For this kind of casting, the distribution of defects

is quite homogeneous, but there is a strong effect due to the process. The ranking of radiographic quality is the following:

$$SC = LPDC > GDC > HPDC.$$

The sectioning of the covers (Fig. 9) confirms, without any doubts, this ranking.

Microstructural investigations

Various kinds of microstructural investigations have been carried out:

- metallographic observation,

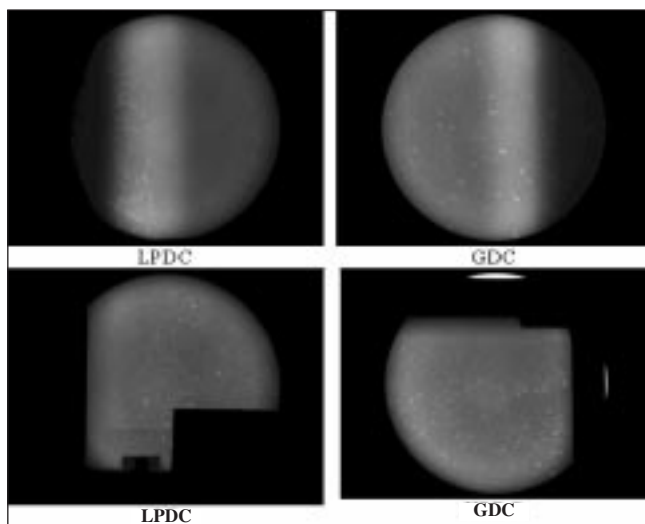


Fig. 6 – Radiographs of the boxes.

Fig. 6 – Radiografia delle scatole di sicurezza.

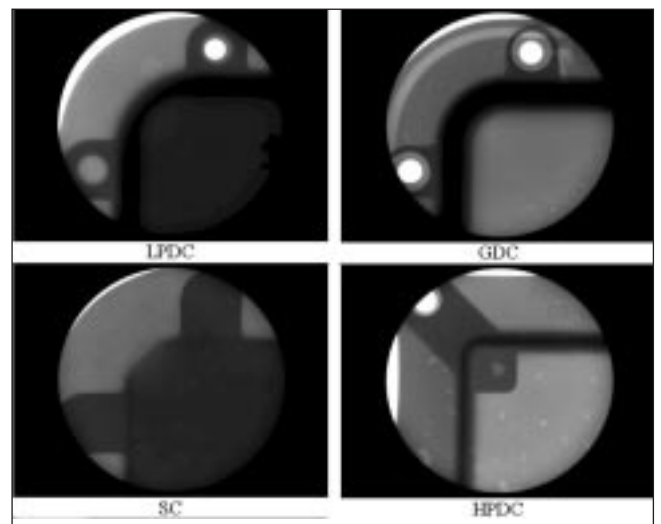


Fig. 7 – Radiographs of the covers.

Fig. 7 – Radiografia dei coperchi di sicurezza.

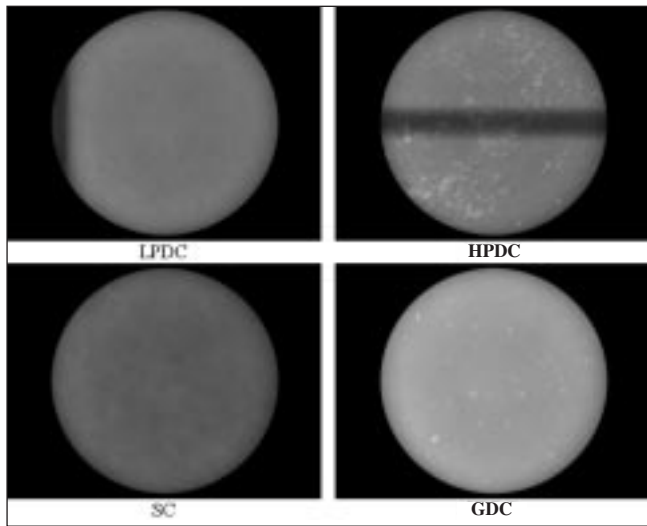


Fig. 8 – Radiographs of the covers.

Fig. 8 – Radiografia dei coperchi di sicurezza.



Fig. 9 – Macroscopic examinations of the covers after sectioning.

Fig. 9 – Esame macroscopico dei coperchi dopo il sezionamento.

- evaluation of porosity characteristics and content,
 - evaluation of Secondary Dendrite Arm Spacing (SDAS).
 The investigations have been performed in the most representative zones of the castings, following the denomination shown in Fig. 10.

Metallographic observation allowed to qualitatively describe the peculiarities of the different casting processes under investigation and of the alloys employed. Fig. 11a is referred to the low pressure die cast cover: a fine dendritic structure (α -Al phase) can be observed, embedded into an Al-Si eutectic “matrix”. In the case of gravity die casting (Fig. 11b), the alloy solidifies into a mostly eutectic structure, even if there is some evidence of primary Si and α -Al grains. The size of such grains, however, is bigger than that found in low pressure die cast material. The gravity sand cast alloy (Fig. 11c) presents a coarse microstructure, associated to longer solidification times with respect to other processes. Big sized Si needles are evident, together with α -Al grains. Finally, the high pressure diecast alloy (Fig. 11d) shows a very fine structure, mainly constituted by the Al-Si eutectic; α -Al dendrites can be detected, as well as spherical porosity, which is typically due to gas entrapment phenomena occurring during this process.

From the micrographic examinations, some aspects related to the dynamics of solidification phenomena can be highlighted. Let's consider the low pressure diecast components. The features of dendrites, and particularly their size, are an index of solidification time. Fig. 12 compares the dendrites typically found in the most far region from the ingate (zone Z3) and in the closest (zone Z5) of the safety box. In low

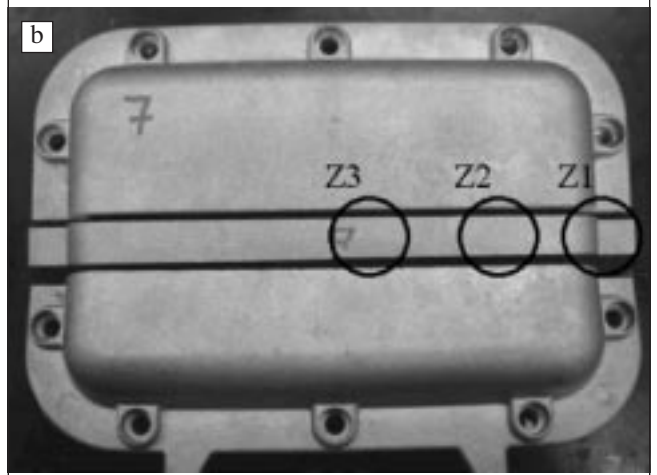
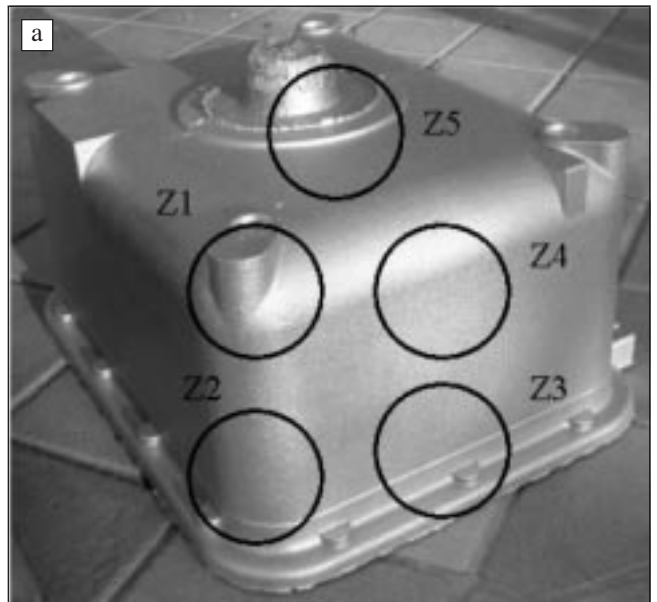


Fig. 10 – Definition of the regions to be investigated in the safety box (a) and cover (b).

Fig. 10 – Definizione delle regioni da analizzare nel recipiente (a) e nel coperchio (b).

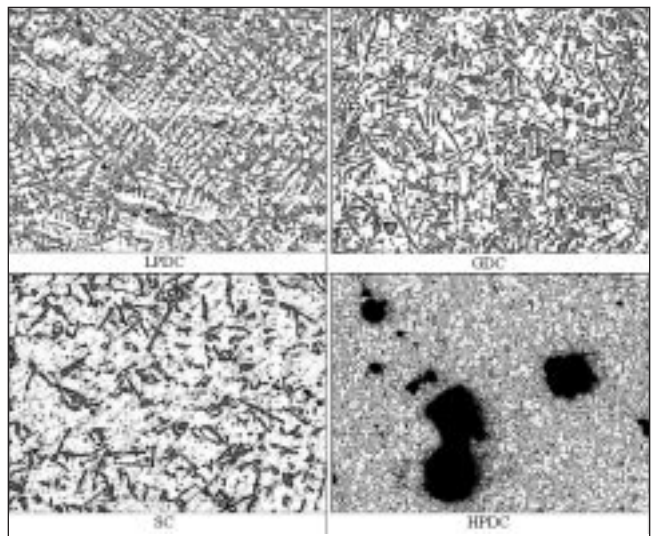


Fig. 11 – Typical microstructure in the safety covers, as a function of the alloy and of the process.

Fig. 11 – Microstruttura tipica nel coperchio di sicurezza, in funzione della lega e del processo.

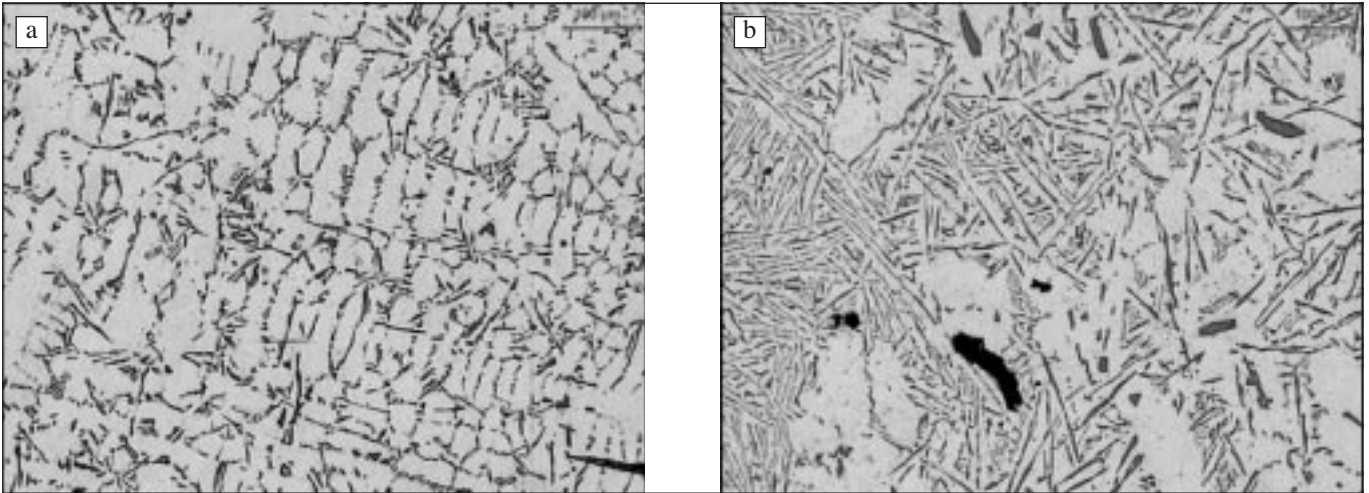


Fig. 12 – Microstructure in LPDC safety box: region Z3 (a) and region Z5 (b).

Fig. 12 – Microstruttura nel contenitore colato in bassa pressione: regione Z3 (a) e regione Z5 (b).

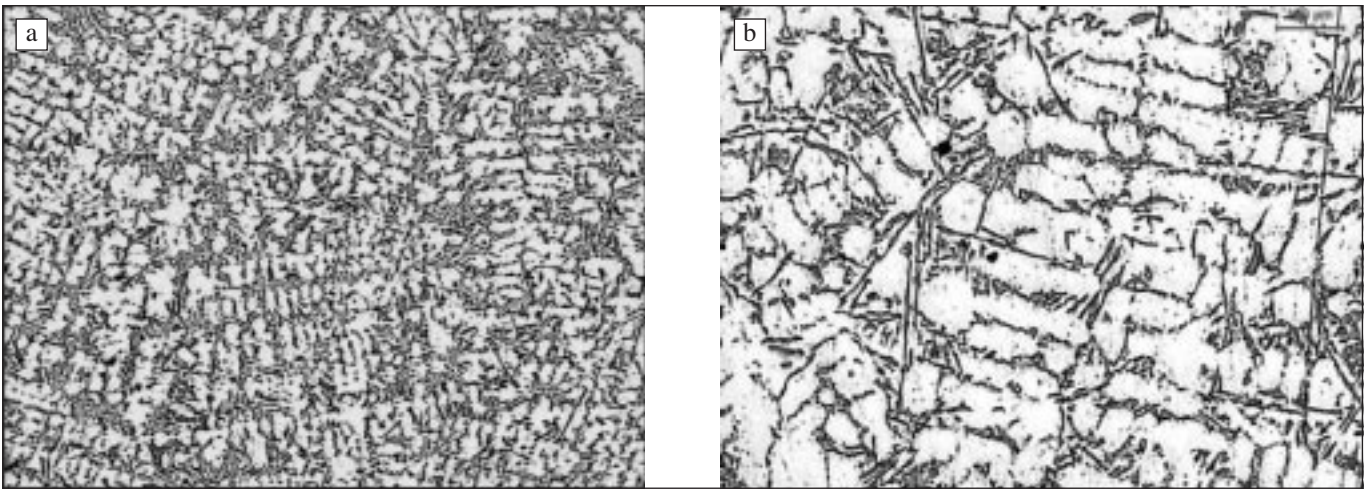


Fig. 13 – Microstructure in LPDC cover: region Z1 (a) and region Z3 (b).

Fig. 13 – Microstruttura nel coperchio colato in bassa pressione: regione Z1 (a) e regione Z3 (b).

pressure diecasting configuration, the ingate can be considered as a “virtual” feeder: near to it, long solidification time is expected, leading to a coarse microstructure. Fine dendrites can be easily seen in regions far from the ingate, in which solidification rate is certainly higher. Similar considerations can be done for what concerns the covers.

Fig. 13 compares the microstructure in the external region (Z1) and in the central one (Z3), which is very close to the ingate. The “qualitative” results of micrographs have been converted into quantitative information by means of SDAS measurements. Table 1 collects the results. By means of image analysis, the average size of defects and

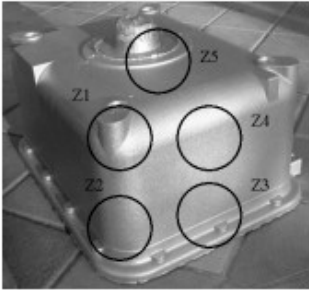
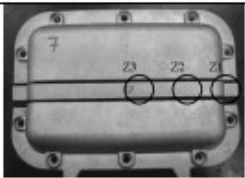
	Component	Region	SDAS (µm)	
			External	Central
	Low pressure diecast safety box	Z1	27,6	36,4
		Z2	22,8	25,7
		Z3	21,0	22,9
		Z4	22,6	28,8
		Z5	--	33,1
	Low pressure diecast cover	Z1	23,7	27,4
		Z2	34,8	41,9
		Z3	33,9	44,9

Table 1 – SDAS values for LPDC components.
Tabella 1 – Valori del parametro SDAS per i getti colati in bassa pressione.

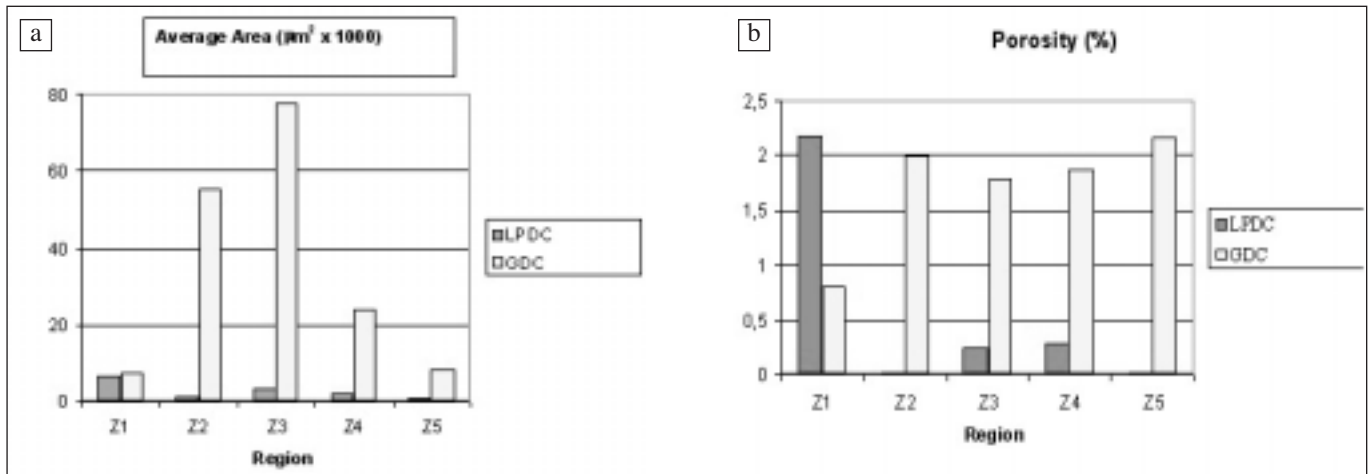


Fig. 14 – Average area of pores (a) and porosity content (b) in safety box as function of process.

Fig. 14 – Area media dei pori (a) e contenuto di porosità (b) nel contenitore di sicurezza, in funzione del processo.

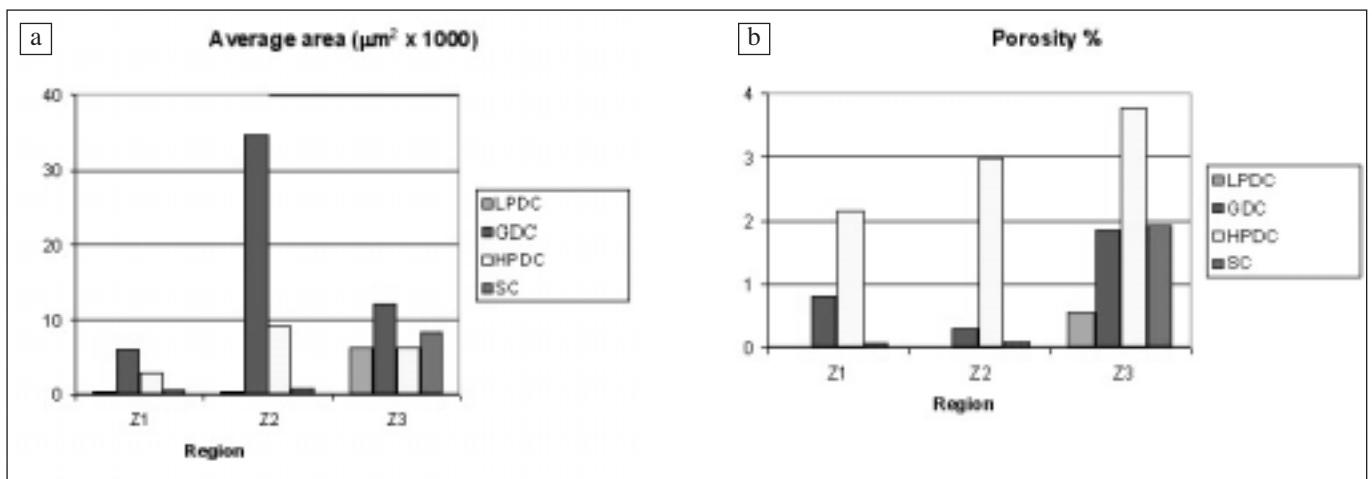


Fig. 15 – Average area of pores (a) and porosity content (b) in safety cover as function of process.

Fig. 15 – Area media dei pori (a) e contenuto di porosità (b) nel coperchio di sicurezza, in funzione del processo.

the porosity content have been detected for all the castings under investigation. Figs 14 and 15 summarise the results.

For what concerns the safety box cast by LPDC, the most critical region is Z1, i.e. that of the corner: the amount of porosity is about 2%. In the other regions, the porosity is always significantly lower than 0.3%. The porosity content and the average area of pores are significantly higher in gravity diecast boxes. In fact, the amount of porosity ranges from 0.8 to 2.2%, according to the region considered. Apart from region Z1, in which porosity size is similar between LPDC and GDC, in all the other regions of the gravity diecast box present cavities with size 10 to 25 times bigger than those detected in low pressure diecast box. The averaging, carried out on all regions, gives for LPDC a porosity content of 0,54% versus a porosity content of 1,72% for GDC.

Similar results have been achieved also for covers, showing a quite good agreement with the results of radiographic inspections. In terms of porosity size, the most critical situation is that of GDC, followed by HPDC, SC and LPDC. In terms of porosity amount, the most critical process, as expected, is HPDC (typically ranging from 2 to 4%), followed by GDC, SC and LPDC. In detail, LPDC shows a porosity content lower than 0,01% in Z1 and Z2.

It is also useful to consider in a deeper way the data. Porosity can be “operatively” divided into two categories, i.e. macro-porosity (intended as that detectable by stereographic microscope) and micro-porosity (intended as that detectable only by optical microscopy). The threshold between micro-

Region	Porosity	LPDC	GDC	SC	HPDC
Z1	Micro	0,004	0,048	0,072	0,557
	Macro		0,76		1,59
	Total	0,004	0,81	0,072	2,15
Z2	Micro	0,005	0,002	0,108	0,232
	Macro		0,30		2,74
	Total	0,005	0,30	0,108	2,98
Z3	Micro	0,055	0,061	0,069	0,534
	Macro	0,50	1,80	1,86	3,24
	Total	0,56	1,86	1,92	3,78

Table 2 – Average porosity content in safety covers.

Tabella 2 – Contenuto medio di porosità nei coperchi di sicurezza.

and macro-porosity area has been fixed at 3000 µm². Table 2 collects the results, showing that the quality of GDC and HPDC is strongly decreased by macro-porosity. LPDC typically presents micro-porosity, and in really low amount. The overall casting porosity is 0,19% for LPDC, 0,70% for SC, 0,99% for GDC and 2,97 % for HPDC.

Hardness tests

Brinell hardness tests have been carried out in regions near (Z5 for the safety box, Z3 for the cover) to the ingate and far (Z3 for the safety box, Z1 for the cover) from it. Casting we-

Casting	Region	HB
Safety box - LPDC	Z3	67
	Z5	63
Safety box - GDC	Z3	50
	Z5	49
Cover - LPDC	Z1	67
	Z3	67
Cover - HPDC	Z1	79
	Z3	65
Cover - SC	Z1	53
	Z3	54
Cover - GDC	Z1	58
	Z3	57

Table 3 – Results of hardness tests.

Tabella 3 – Risultati delle prove di durezza.

re tested in as-cast conditions, i.e. without any heat treatment. The difference in hardness values (which are displayed in Table 3) are due to the alloy and to the different

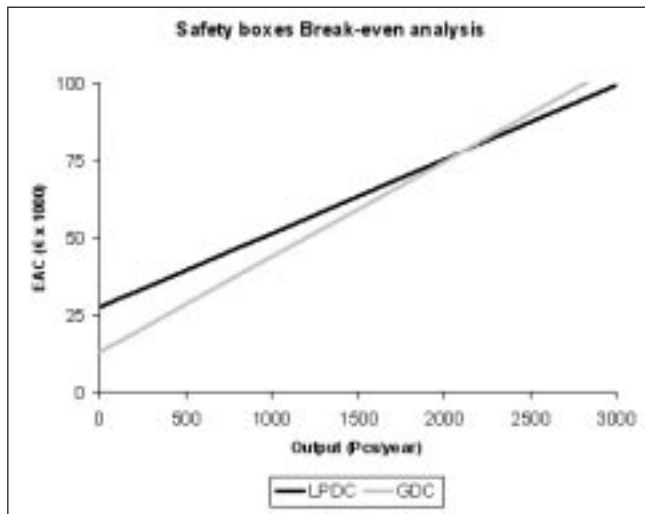


Fig. 16 – Graphic determination of Break-even point for safety boxes.

Fig. 16 – Determinazione grafica del Break-even point per i contenitori di sicurezza.

	LPDC	GDC
Investment (€)	200000	100000
Die cost (€)	16000	16000
Stalk (rising tube) (€)	1500	-
Aluminium cost* (€/kg)	1,58	1,58
Weight of casting (kg)	13	13
Yield	0,99	0,73
Production time (h/pc)	0,088	0,15
Scrap	0,03	0,05
Cost of labour (€/h)	15	15
Preliminary treatments	Melting in gas furnace, TiB grain refinement, degassing, electric furnace maintenance	Melting in gas furnace, TiB grain refinement, degassing, electric furnace maintenance
Riser removal (€/pc)	0,90 (carried out on automatic work centre)	Manual (riser cutting and deburring)
Downstream working	Sand-blasting	Sand-blasting
Recycled Al value (€/kg)	-	0,70

Table 4 – Data for Break-even analysis for safety boxes.

Tabella 4 – Dati per la Break-even analysis relativa al contenitore di sicurezza.

microstructure achieved. HPDC presents the higher hardness thanks to the high Si content of the alloy, together to the fine structure deriving from high cooling rates. LPDC castings show hardness values ranging from 63 to 67 HB.

ECONOMICAL CONSIDERATIONS

Through experimental analysis, the technical potential of LPDC for the production of box and covers has been demonstrated. The further aspect to be investigated to the cost of the quality of LPDC process, which is the key-point for industrial feasibility.

Safety box: determination of Break-even Point and structure of costs

First of all, it has to be determined the production rate that makes one process cheaper than the other, using the Break-even analysis, under the hypothesis that a new casting machine has to be acquired, choosing between LPDC and GDC. This means that the analysis considers two alternatives with identical aim and equal service life. The data used for the Break-even analysis are shown in Table 4.

Analysing cost items, it clearly appears that the initial expense for LPDC (higher than GDC) corresponds to a higher yield and a reduced production time. Stalk (rising tube) is a cost item typical of low pressure technology, and can be considered as a fixed cost. After the extraction from the die, the casting follows different path, depending on the process. The LPDC casting is loaded on an automatic work centre that removes the ingate in 1 minute, with an estimated cost of 0,90 €. This operation requires 1 minute of workman to load and unload the piece. The GDC casting is subjected to a manual machining, consisting of a cutting of the riser and a subsequent deburring. These operations require 5 minute of workman in total. The item “recycled Al value” represents a deduction in the calculation concerning the GDC solution. It consists in the scrap material (solidified risers and feeders) resold to remelting and refining companies. An interest rate of 5% is used in Break-even analysis.

The output of such analysis is reported in Fig. 16, showing the Break-even point, for the safety box under study, at 2143 pcs/year.

The formula used in the calculation of Break-even point is (1):

$$q = \frac{CF_{lpdc} - CF_{gdc}}{\left[(1 + S_{gdc}) \cdot \frac{W_{gdc} \cdot C_{Al}}{Y_{gdc}} + PT_{gdc} \cdot C_l + \frac{1}{12} \cdot C_l - (1 - Y_{gdc}) \cdot W_{gdc} \cdot V_{Al} \right] - \left[(1 + S_{lpdc}) \cdot \frac{W_{lpdc} \cdot C_{Al}}{Y_{lpdc}} + PT_{lpdc} \cdot C_l + \frac{1}{60} \cdot C_l + RR_{lpdc} \right]}$$

in which:

- CF = fixed costs
- S = scrap
- W = weight of casting
- C_{Al} = Aluminium cost (raw material)
- Y = yield
- PT = production time
- C_l = cost of labour
- V_{Al} = recycled Al value
- RR = riser removal

Fixed costs of LPDC option are reckoned as follows:

- Machine allowance, for 10 years of lifetime, interest rate of 5%, null final value of the machine (at most it is considerable the value of recycling the steel that build up the machine)
- Die allowance, for 10 years of lifetime, interest rate of 5%, null final value of the die
- Stalks consumption.

Fixed costs of GDC solution are reckoned with the same method of LPDC, except for the last item, which obviously is not considered. The value "1/12" in (1) takes into account the time (expressed in hours) needed for manual operations of cutting and deburring, as well for the value "1/60" concerning LPDC.

From the production data representing the Break-even point (in this way the absolute value of unit cost is the same for both techniques), the cost structure can be determined, and is shown in Fig. 17. It can be seen that raw material cost in LPDC has lower relevance with respect to GDC (59% instead of 76%), thanks to the better process yield. On the other hand, machine allowance represents a significant part of total cost in LPDC (35% versus 15%), due the higher initial investment. Difference in cost of labour amount is the result of a different production time: LPDC production time is 41% lower than GDC.

However, safety boxes can be produced in different size, and it is interesting to see the effect of this parameter on the definition of the Break-even Point. Some examples are col-

Case	Box weight	Break-even point
A	6,9	3558
B	13,0	2143
C	21,5	1034
D	35,0	725

Table 5– Break-even Point as a function of safety box weight.

Tabella 5– Andamento del Break-even point in funzione del peso del contenitore di sicurezza.

	LPDC	GDC
Casting weight (kg)	6	6
Yield	0,99	0,80
Product time (h/pc)	0,067	0,15
Riser removal (€/pc)	0,80	Manual

Table 6 – Data for Break-even Analysis for safety covers.

Tabella 6 – Dati per la Break-even Analysis relativa al coperchio di sicurezza.

lected in Table 5: as casting weight increases, the value of balance is reduced, because of the advantageous yield of LPDC with respect to GDC.

Safety cover: determination of Break-even Point and structure of costs

A similar approach can be adopted to evaluate the potential of LPDC in the production of covers. The different data used in this Break-even analysis (with respect to the previous one) are shown in Table 6. Main difference lies in the yield of GDC safety cover, which is higher than for GDC safety box, because cover is smaller and more geometrically simple than box, so it needs smaller risers. Fig. 18 shows the graphic determination of Break-even point, which has been calculated to be 4531 pcs/year, by using equation (1). Also in this case, the Break-even point decreases as the casting weight increases (Table 7).

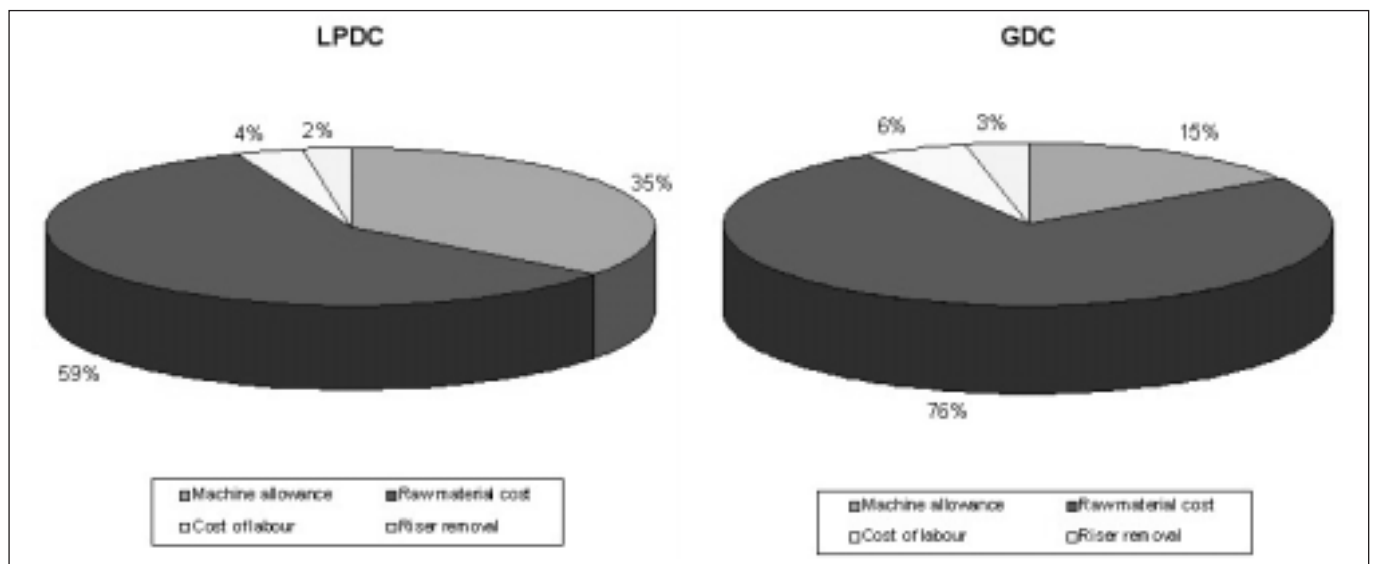


Fig. 17 – Unit cost structure of LPDC and GDC safety boxes.

Fig. 17 – Struttura unitaria dei costi per i contenitori di sicurezza prodotti per colata in bassa pressione e in gravità.

Case	Box weight	Break-even point
A	3,2	6077
B	6	4531
C	12	2637
D	16,7	2112

Table 7 – Break-even Point as a function of safety cover weight.

Tabella 7 – Andamento del Break-even point in funzione del peso del coperchio di sicurezza.

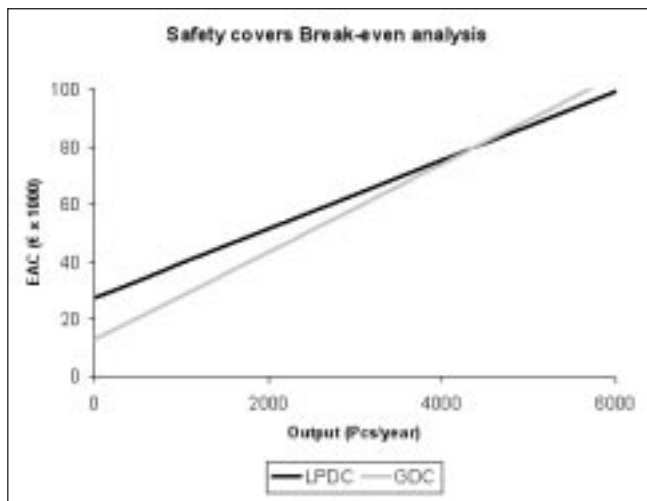


Fig. 18 – Graphic determination of Break-even point for safety covers.

Fig. 18 – Determinazione grafica del Break-even point per il coperchio di sicurezza.

Likewise in the previous case, Fig. 19 shows unit cost per cent composition of safety covers, reckoned at balance output. Remarks done on Fig. 17 are still valid. It is evident that the gap in terms of raw material cost becomes thinner, because the GDC cover yield is higher than the GDC box yield.

FINAL CONSIDERATIONS

From the technical investigations and the economical evaluations carried out, some concluding remarks can be done.

- 1) The LPDC process allows the achievement of castings with very good soundness and metallurgical quality. Inside the group of components studied, the ranking of quality is LPDC > SC > GDC > HPDC
- 2) LPDC is characterised by a high yield, leading to an optimal use of the alloy and consequently in relevant cost savings.
- 3) With specific reference to LPDC and GDC, which have been deeply investigated from the economical point of view, they present a different structure of the costs; in particular, LPDC assures a strong decrease in costs associated to raw material, needing, on the other side, higher equipment costs.
- 4) The Break-even point, in terms of number of pieces/year for which LPDC starts to become convenient with respect to GDC, depends obviously on casting weight and geometry; however, in the case studied, it can be set at about 2000-2500 pieces/year for a 10 kg casting; it decreases to 1000-1500 pieces/year for a 20 kg casting. From these consideration, it can be argued that LPDC really presents a relevant potential, which can be exploited in new and various field and applications.

REFERENCES

- [1] ASM Metals Handbook, 10th ed., vol. 15: "Casting", ASM - Metals Park, Ohio (1990).
- [2] J. CAMPBELL, R. A. HARDING, "Casting Technology" in TALAT 2.0 cd-rom, EAA, Bruxelles (2000).
- [3] J. CAMPBELL, "Castings", Butterworth, Oxford (1991).
- [4] A. PERRONE, F. BONOLLO, V. WAGNER, Alluminio Magazine, 4 (1998), pp 32-41.
- [5] S. SCHLEG, D.P. KAMICKI, "Guide to casting and moulding processes", Engineered casting solutions, Technical articles (2000).
- [6] J.R. BROWN, "Non-ferrous foundryman's handbook", Butterworth, Oxford (1999).
- [7] G.S. COLE, A.M. SHERMAN, Materials Characterization 35 (1995), pp. 3-9.
- [8] A.C. STREET, The diecasting book – 2nd edition, Portcullis Press (1990)
- [9] T. YAMADA, H. USUI, H. TOSA, H. TERAUCHI, J.G. CONLEY, SAE Technical Paper Series N° 920572 (1992), pp. 1-14
- [10] F. BONOLLO, S. ODORIZZI, Numerical Simulation of Foundry Processes, SGE, Padova (2001)

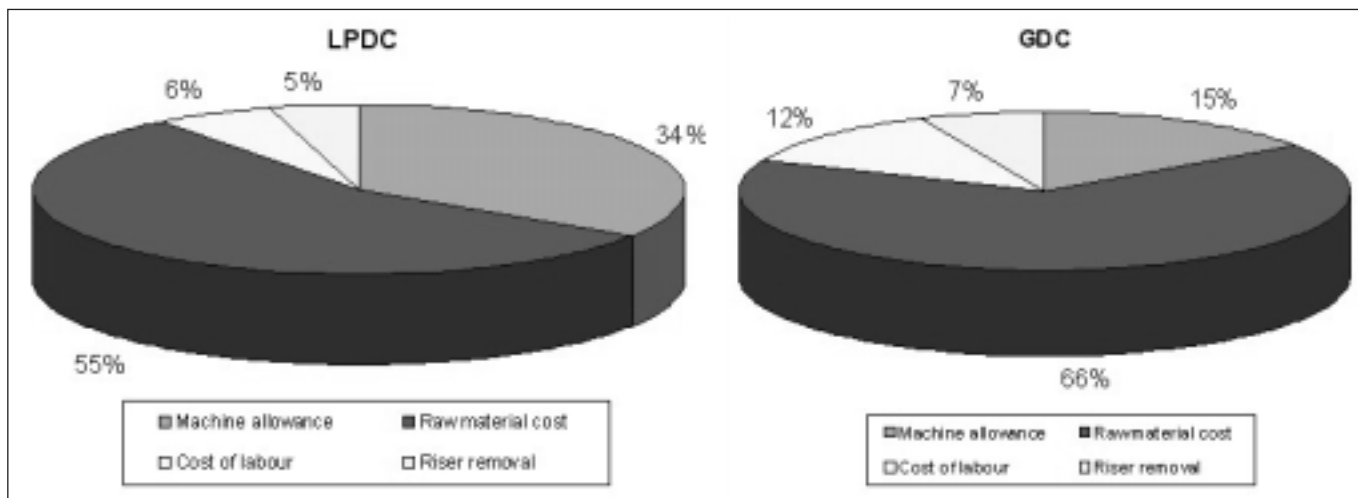


Figure 19 – Unit cost structure of LPDC and GDC safety covers.

Fig. 19 – Struttura unitaria dei costi per i coperchi di sicurezza prodotti per colata in bassa pressione e in gravità.

**COLATA IN GRAVITÀ E IN BASSA PRESSIONE
DI LEGHE DI ALLUMINIO:
UN CONFRONTO TECNICO ED ECONOMICO**

Parole chiave:

alluminio e leghe, difetti, fonderia, caratterizzazione materiali, impianti e attrezzature

Tra i vari processi, convenzionali e innovativi, di fonderia dell'alluminio (Fig. 1), la colata in bassa pressione (low pressure die casting, LPDC), il cui principio di funzionamento è descritto nelle Figg. 2 e 3, è caratterizzata da svariati vantaggi:

- elevata resa,
 - eccellente controllo dei parametri operativi,
 - buona qualità metallurgica e tecnologica dei getti.
- Sono numerose le tipologie di getti ottenibili (Fig.4), anche se finora il processo è stato prevalentemente applicato al settore automobilistico. In questo lavoro viene illustrato il potenziale tecnico ed economico della colata in bassa pressione finalizzata alla produzione di contenitori e coperchi di sicurezza per l'industria chimica e petrolchimica (Fig. 5). Tali componenti sono prodotti da ELFIT SpA ricorrendo a differenti processi. Oltre alla bassa pressione, nel caso dei contenitori viene usata la colata in gravità in conchiglia (gravity die casting, GDC). Per i coperchi, oltre ai due processi citati, vengono usati anche la colata in sabbia (sand casting, SC) e la pressocolata (high pressure diecasting, HPDC). Le leghe impiegate sono le seguenti
- EN AB-43000 (AlSi10Mg) per il processo LPDC;
 - EN AB-44100 (AlSi13) per il processo GDC;
 - EN AB-47100 (AlSi12) per il processo HPDC;
 - EN AB-42000 (AlSi7) per il processo SC.

Le indagini radiografiche e macrografiche (Figg. 6-9) hanno dimostrato, per i coperchi di sicurezza, la seguente "gra-

duatoria" di qualità: $SC = LPDC > GDC > HPDC$.

Le indagini microstrutturali (metallografia + analisi di immagine) sono state effettuate nelle regioni indicate in Fig. 10. Le microstrutture tipiche dei getti sono illustrate nelle Figg. 11-13, mentre la Tab. 1 illustra i valori della spaziatura dendritica secondaria (secondary dendrite arm spacing, SDAS) nelle varie regioni dei getti prodotti per LPDC.

Nelle Figg. 14-15 e in Tab. 2 viene invece riportata la sintesi delle misure di porosità. Nei contenitori di sicurezza, si ha un valore medio pari allo 0,54% per il processo LPDC e all'1,72% per il processo GDC. Nel caso dei coperchi, si ha un contenuto di porosità di 0,19% per LPDC, 0,70% per SC, 0,99% per GDC e 2,97% per HPDC.

Sono state effettuate anche prove di durezza, i cui risultati sono raccolti in Tab. 3.

In termini economici sono stati invece determinati i valori di produzione che rendono un processo più conveniente rispetto all'altro, utilizzando la Break-even analysis, sotto l'ipotesi voler confrontare LPDC e GDC dovendo acquistare una nuova macchina. I dati di input dell'analisi sono raccolti nelle Tabb. 4 e 6. A fronte di un maggior investimento iniziale per la macchina LPDC, si ottengono con questo processo una resa più elevata e tempi ciclo più brevi. Il Break-even point a vantaggio della LPDC, nel caso dei contenitori di sicurezza, si ha in corrispondenza ad una produzione di 2143 pezzi/anno (Fig. 16), con la struttura unitaria dei costi descritta in Fig. 17. Come illustrato in Tab. 5, il valore del Break-even point è funzione del peso del getto.

Nel caso dei coperchi di sicurezza, il break-even point a favore del processo LPDC si ha a 4531 pezzi/anno (Fig. 18); l'effetto del peso del getto è sintetizzato in Tab. 7, mentre in Fig. 19 è riportata la struttura dei costi.

In definitiva, il potenziale del processo LPDC si presenta davvero significativo, anche per la produzione di componenti per settori differenti da quello automobilistico.